



# **LOOP<sup>®</sup> TYPE 3**

## INSTALLATION MANUAL

# GENERAL INFORMATION

## GENERAL INFORMATION

This assembly manual addresses all metal ceilings manufactured by durlum. The different sections describe the related/relevant products.

durlum is a leading German manufacturer of metal ceilings and cladding elements, mainly made of galvanised sheet steel, aluminium and expanded metal.



The relevant products are described in the marketing and sales documents. They are both acoustically effective, and can also be used as design elements only. Specifically, these products are:

- Acoustic ceilings
- Chilled ceilings
- CHARACTER products

durlum differentiates between a wide range of ceiling systems, for example S1. "S1" stands for system 1 clamping. In this system, there are different nomenclatures that allow a further subdivision of the systems.

All durlum systems are systems of modular design. This applies not only to the substructure but also the ceiling parts that are suspended, locked into place or placed on the substructure.

durlum metal ceilings comply with the standard EN 13964:2007 and are CE-certified.

Appropriate static certificates are available for special systems marketed by us and for which no general approvals are available, and appropriate designs compliant with EN 13964 have been constructed. durlum lamps comply with standard EN 60598-1 and are CE-certified.

## GUIDELINES

These installation instructions have been structured in accordance with the requirement of EN 13964:2007 and describe a proper assembly.

The description does not exempt the user from examining the structural conditions, implementing the building code regulations and observing the information given in the building permit prior to starting assembly. They have priority, but could not be included here.

It is advisable always to draw up assembly diagrams/drawings, to establish the location where assembly is to begin and to establish the required suspension points for the relevant ceiling system prior to starting assembly.

## STRUCTURAL PRECONDITIONS

Metal ceilings may usually be installed as soon as the building is swept clean, but at least when all wet work in the interior has been completed and the building has been closed.

Prior to starting assembly, the suspension points must be checked for their usability, and load introduction into the building must be guaranteed.

When using wall mounting points, such as brackets or wall anchors, the load-carrying capacity of the wall in question must be checked.

If ceiling elements rest on brackets, possible wall movements must be taken into account.

Only anchors for which a general building supervisory approval is available may be used, and their minimum extraction force must be greater than 100kg. The anchors must be mounted as specified by the relevant anchors manufacturer. We recommend performing regular tensile stress tests, to verify that anchors have been set correctly.

durlum metal ceilings are dimensioned such that they carry their own weight of the system construction plus a surface load amounting to 40N/m<sup>2</sup>. Higher loads must be taken into account or suspended separately in the construction, and the measures must be adapted to the situation at hand. Usually, built-in components and loads must be suspended separately.

For ceiling systems that do not allow any tolerance compensation within a module,

suitable material expansions must be taken into account.

Building expansion joints and tolerances customary in building construction must be taken into account accordingly.

durlum metal ceilings must always be assembled by expert dry building companies who are capable of assessing the overall situation in the building, the metal ceiling, the cladding surface, as well as the structural conditions and are able to take suitable precautions for ensuring proper assembly.

If parts from different manufacturers are used to assemble the ceiling, the relevant mounting company must provide the certificates required by EN 13964:2007 and must obtain suitable certificates of conformity itself.

Liability for proper selection of the products and system conformity can only be assumed for the systems delivered by durlum.

To prevent the parts from becoming dirty, gloves must be worn during assembly. If the ceiling products are delivered laminated with a protective film, they must be protected from exposure to UV radiation [sunlight], the film must likewise be removed from the goods no later than 4 weeks after delivery, and the storage temperature must not exceed 30°, since otherwise the adhesive on the panel may become hardened, and the protective film can no longer be removed.

## STORAGE

durlum metal ceilings are usually delivered on pallets. It is advisable to leave the metal panels on the pallets as long as possible. If the pallets need to be opened, the durlum POLYLAM® should always be placed on its underside.

Storage must be carried out such that damage is excluded.

The assembly of the ceiling panels must not start until all dust-producing work has been completed [swept clean].

durlum products are certified according to ISO 9001 for development, production, sales and also for service. Nevertheless, it is recommended to always subject the metal ceilings immediately to an inspection and to report any complaints right away [usually immediately following delivery or within 3 days]. Visible damage must be noted on the delivery note.

## STANDARDS AND REGULATIONS

The relevant regulations applicable at the installation site must be determined by the assembly company in question. The ceilings marketed by durlum conform to EN 13964. This standard also governs fire behaviour in accordance with EN 13501.

## APPLICATION

The application of durlum metal ceilings is restricted, unless agreed upon otherwise, to interiors, so that, pursuant to EN 13964, class of use 1, corrosion protection class A, has been defined here as standard. The use of durlum lighting is restricted to interiors. The lighting complies with protection class IP 20, protection class 1 according to EN 60598-1.

Should it become necessary to adjust the metal ceiling panels to the building by cutting, we recommend protecting the cutting edges from corrosion by means of a paint, to maintain the corrosion protection class A.

## QUALITY STANDARD

For material properties, dimensions, tolerances, colour deviations, the TAIM Directives [Technical Association of Industrial Metal Ceiling Manufacturers] applies.

## MOUNTING SEQUENCE

1. Prepare ceiling- and lighting installation plan or adopt architect's plan.
2. Check ceiling lighting installation plan versus structural conditions.
3. Prepare a bill of materials, including a suitable work plan and retrieval/order of the materials required.
4. Determine the required suspension points in accordance with the classes of use of EN 13964. The corresponding suspension distances for the different systems can be taken from the detailed descriptions of the individual ceiling systems.
5. Establish which generally approved anchor is suitable. Check the raw ceiling and the walls. Mark the anchor mounting holes and drill them. Mount the anchors as specified by the anchor manufacturer and carry out extraction tests using the device recommended by the anchor manufacturer, if necessary.

6. Use the same procedure when mounting the wall brackets, mounting distance about 400–625mm, check the introduction of force into the wall.
7. Shorten intended fastening elements, such as the M6 threaded rod or the nonius hanger to the intended length or order the correct length and mount it on the raw ceiling.
8. Usually, the panel layout should be started from the centre of the room, in order to be able to compensate the tolerance of the room and cut the panels in half, if necessary. The precise arrangement must always be done on the basis of the ceiling layout plan.
9. durlum metal ceilings are usually provided with a cross support [primary profile].
10. Use the layout plan to determine in which direction the cross reinforcement profiles are laid, either in parallel to the façade [usually] or vertically to the façade. The cross reinforcement profiles should be mounted via a wall anchor or via a diagonal anchoring to prevent an axial movement. The corresponding primary profiles are mounted at right angles to the secondary profiles. To this end, the system-specific connecting elements are used, see system descriptions. The position of the primary profiles is established in the reflected ceiling plan.
11. The metal ceiling panels are often provided with a joint tape [9x3mm], to make for easier tolerance compensation. Should a joint tape be used, the joints must also be re-aligned from time to time, since the joint tape also has tolerances. However, owing to the high production precision, it is also possible to connect the panels without a joint tape by using butt joints or provide them with rubber spacer naps. Always ensure that the joints are aligned.
12. If the panels are placed on a perimeter trim, we recommend our F-bracket as bracket or as stepped F-bracket. The bracket secures the panel and protects it against lifting. The ceiling panel is cut with electric sheet shears [i.e. Treco shears] and adapted to the prevailing room dimensions. When calculating the minimum support area [10mm], the dimensions of possible wall movement should be taken into account.
13. Attachments or other loads are to be mounted separately. For logical reasons these parts are integrated during the mounting process.
14. After completion and pre-acceptance of the ceiling, the sequence of joints should be re-aligned. Soiled ceiling panels should be cleaned to give a perfect result for assembly.

# LOOP® TYPE 3 INSTALLATION MANUAL

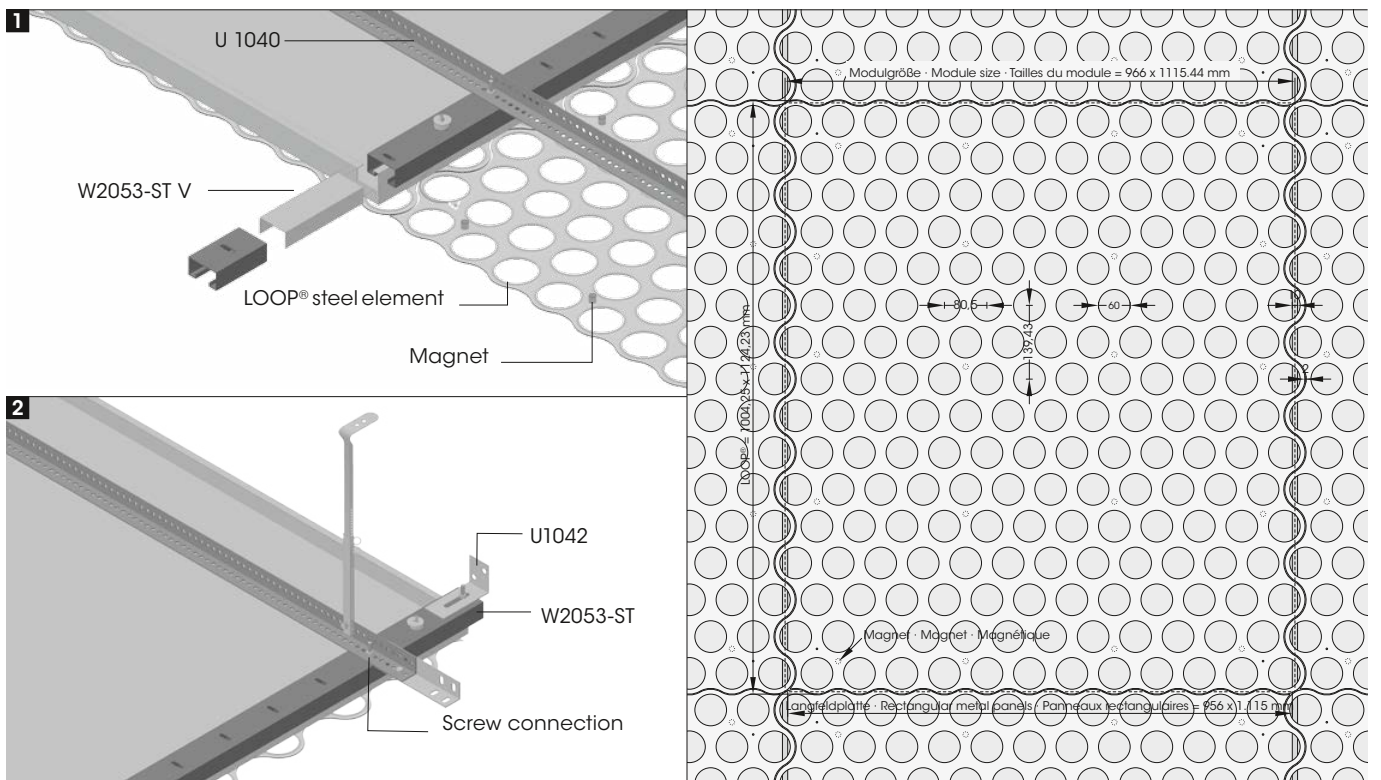
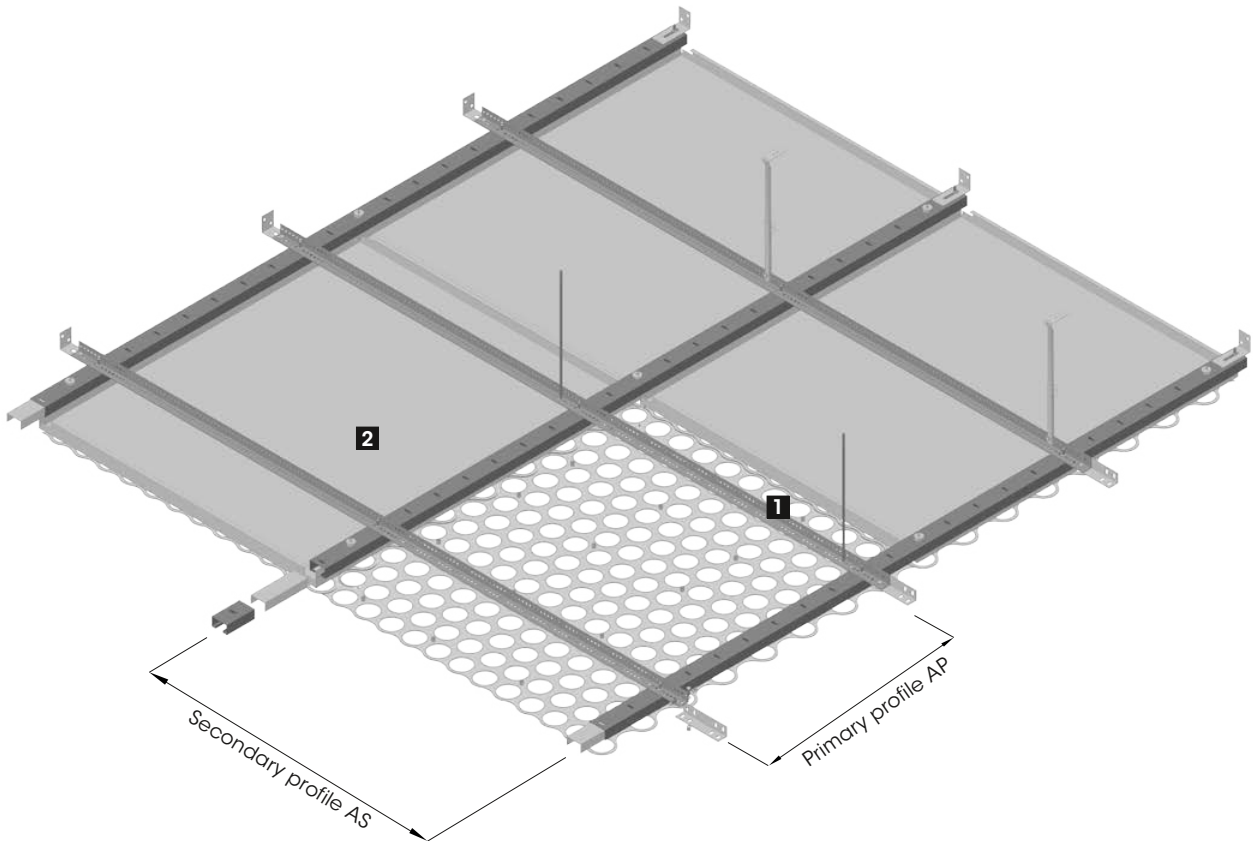

# INSTALLATION MANUAL LOOP® TYPE 3

## ABBREVIATIONS

AH: Distance of the suspension hangers in axial direction of the primary profile  
 AP: Distance of primary profiles U 1040  
 AS: Distance of secondary profiles W 2053-ST

## ASSEMBLY OF THE FALSE CEILING

Note:  
 Please take the S7 KS System Assembly instructions into account. With the following exceptions:

Distance of the primary profile  $\leq 800\text{mm}$

### Assembly of the suspension

Items 1-19 acc. to assembly instructions

#### Item 20

Cut the rail channel W 2053-ST to the required length.

#### Item 21

At the crossing points to the primary profile, the rail channel W 2053-ST is screwed to the L-shaped primary carrier U 1040 using a self-securing screw connection M6.

#### Item 22

The joint formation of the rail channel is performed using the rail channel connector W 2053-ST V.

Items 23 and 24 are withdrawn

## ASSEMBLY OF LOOP® ELEMENTS

1. Wear clean cotton gloves.
2. Preassemble the safety ropes (min. 2 pieces per standard element) as shown on the drawing. Run rope through the damper disc and safety rope anchor disc and secure it in the armature disc by bending the web.

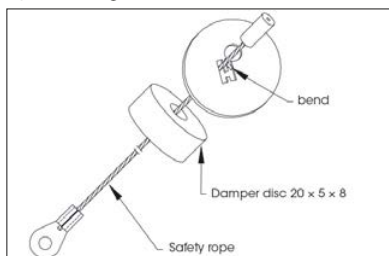

3. Then run the preassembled rope through an elongated hole (in the area of the later fastening points of the safety rope) in the rail channel out of the ceiling void downwards.

4. When assembling the LOOP® elements, the safety rope is screwed to the LOOP® element by means of a wing nut.

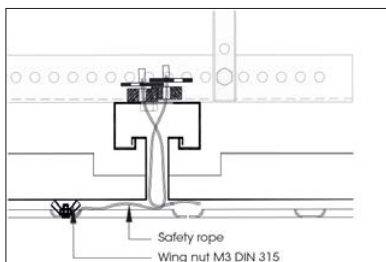

5. Measure the position of the LOOP® element exactly using the laser (longitudinal and transverse rows). Hold the LOOP® element with the rear magnet (20 pieces per standard element) from below horizontally against the ceiling S7 KS (friction force by magnet). For the arrangement of the magnets, see below. To simplify assembly/disassembly, the magnets can be glued to the LOOP® element (e.g. LOCTITE).

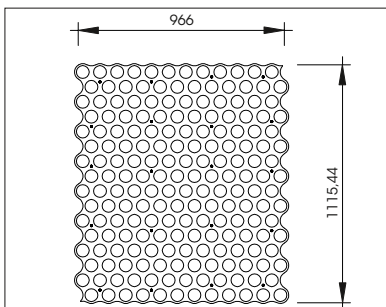

6. The installation is then performed with further elements similar to a puzzle. The elements are to be aligned by sliding them. To do so, the joints of the LOOP® ceiling are aligned horizontally by pushing or pulling the adjacent element. Check the joint between the elements for flatness and uniform width.
7. For connection to the wall, the elements can be simply adapted to the room, using a jigsaw. The cutting edge is covered with a bracket or a plasterboard frieze. In the area of the glass wall, the cut is not covered. Ensure clean cut.

## MOUNTING OF LUMINAIRES

Note:  
 Mounting and electrical connection of the luminaire must be performed by an authorised skilled electrician (e.g. electric installer) in accordance with VDE 0100, taking into account the technical information and the legal regulations in force in your country.

Safe operation of the luminaire is only guaranteed if these instructions are observed. This is why the mounting instructions should be kept in a safe place. The manufacturer

cannot assume any liability whatsoever if the instructions given below are not followed or the luminaire is used improperly.

1. Remove both springs of the PUNTEO®-J85 LED downlight.

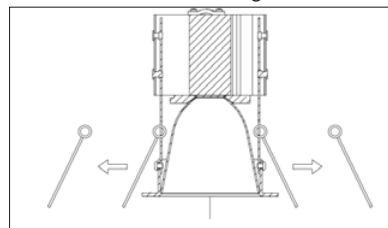

2. When fitting PUNTEO®-J85 LED downlights, a connecting adapter PUN J085-018-Z001 is required, which is glued centrally to the back of the element. Attention: luminaires cannot be mounted in the area of the secondary profiles!
3. Mount ballasts/drivers in the ceiling void, possibly on U 1040.
4. Perform electrical connection of the driver.
5. Ensure that the LOOP® elements are clean and free of grease. To fasten the adapter PUN J085-018-Z001 to the LOOP® element, a primer is required. Note: The primer is not included in the delivery. A primer for non-absorbent substrates, e.g. EVT Primer MK, should be used. Attach primer to the back of the LOOP® in the glued area. Remove the paper from the adhesive tape of the LOOP® adapter PUN J085-018-Z001. Then position and mount the adapter on the back of the LOOP® element. Press the adapter down firmly.

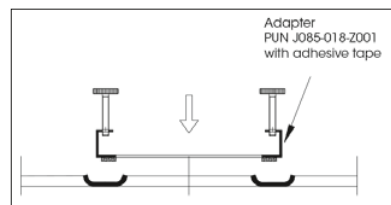

# LOOP® TYPE 3 INSTALLATION MANUAL

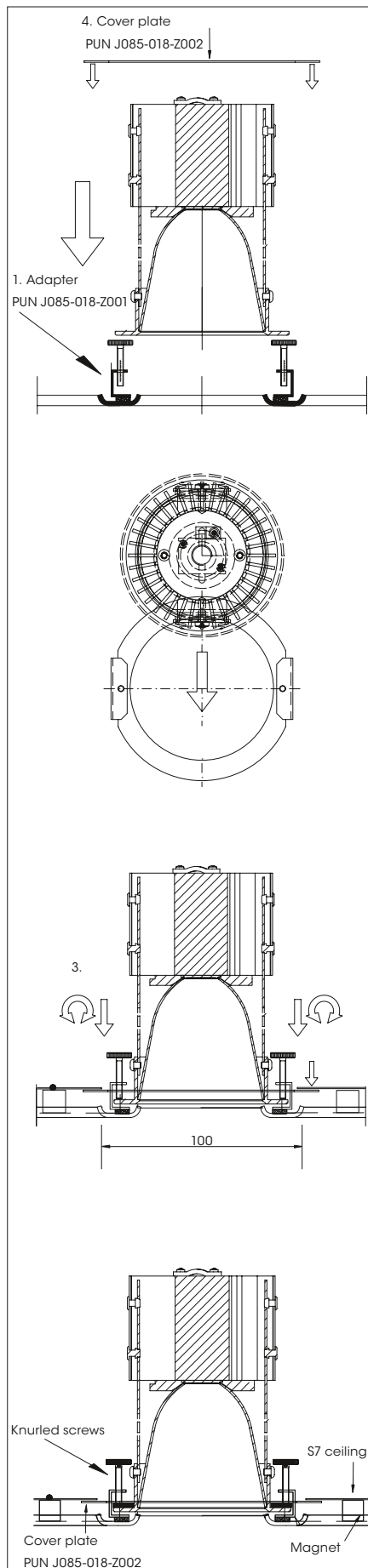

6. Insert PUNTEO®-J85 laterally into the adapter and position it centrally over the hole (2.). Cutout with diameter 100mm in S7 ceiling to be done by others if required. Then fasten the LED downlight with the knurled screws without using tools (3.). Place the cover plate over the PUNTEO®-J85 on the ring (4.).
7. Connect the ballast units/drivers via plugs. If a system is not fitted with a plug, wiring should be carried out by a authorised electrician.
8. Prior to acceptance, align the elements precisely, if they have been moved by other systems.

Note:

The lumininaire must not be coated with a heat-insulating material.



The components are fitted with electronic components, which can become damaged in case of electrostatic discharge. When handling the components, ensure good earthing of the environment.



## DISASSEMBLY OF THE CEILING PANELS

9. Wear clean cotton gloves.
10. Pull LOOP® elements, including PUNTEO®-J85 and their adapter, downwards to overcome their friction force.
11. LOOP® elements, including PUNTEO®-J85 and their adapter, will fall into the safety chain, but must always be held.
12. Release the safety ropes and set down the elements.
13. Open S7 false ceiling in accordance with the S7KS Assembly Instructions.

# DECKE LICHT RAUM

CEILING LIGHTING AMBIENCE  
PLAFOND LUMIERE AMBIANCE

**durlum GmbH** | An der Wiese 5 | D-79650 Schopfheim

T +49 (0) 76 22 | 39 05-0

F +49 (0) 76 22 | 39 05-42

E [info@durlum.com](mailto:info@durlum.com)

I [www.durlum.com](http://www.durlum.com)